

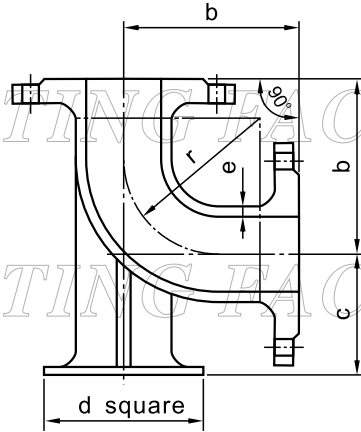

Double Flanged 90° Duckfoot Bends



Unit : mm

Nominal size DN	e	d	r approx.	b	c	Mass with flange (Kg)		
						PN 10	PN 16	PN 25
80	7.0	180	115	165	110	14.1	14.1	14.1
100	7.2	200	120	180	125	17.8	17.8	18.8
150	7.8	250	155	220	160	30.5	30.5	32.5
200	8.4	300	190	260	190	47.4	47.0	51.2
250	9.0	350	275	350	225	76.8	76.0	83.8
300	9.6	400	315	400	255	108.8	108.0	119.2
350	10.2	450	360	450	290	140.8	147.0	163.6
400	10.8	500	405	500	320	184.8	196.0	218.6
450	11.4	550	450	550	355	230.2	246.0	267.8
500	12.0	600	490	600	385	291.6	322.0	345.4
600	13.2	700	580	700	450	443.4	493.0	524.8
700	14.4	800	685	800	515	552.4	586.0	652.0
800	15.6	900	785	900	580	759.6	798.0	896.4
900	16.8	1000	875	1000	645	1002.2	1050.0	1170.8
1000	18.0	1100	965	1100	710	1297.0	1380.0	1535.6
1100	19.2	1200	1055	1200	775	1586.0	1656.0	1801.8
1200	20.4	1300	1145	1300	840	1934.4	2063.0	2262.0